



LENNOX

INNOVATION NEVER FELT SO GOOD.™

## LENNOX' ELITE® SERIES

Home Comfort Systems



### **G61**

Two-stage,  
high-efficiency furnace



# Elite® Series G61 Gas Furnace

Innovation never felt so good.™

Two-stage operation minimizes up-and-down temperature changes

High efficiency can save you hundreds of dollars each year

Low-speed, continuous fan setting provides a quiet, consistent flow of air

ENERGY STAR®-qualified

Unlike typical single-stage furnaces, the G61 has two levels of heat output: low heat for mild days and high heat for extremely cold days. Since the G61 operates at low capacity 80% of the time, it runs more quietly for longer periods and provides more even heat distribution.

## TWO LEVELS OF HEAT, A HIGH LEVEL OF COMFORT

The G61 allows the thermostat to deliver greater comfort control, regulating the temperature to within one degree of the set point.

### TEMPERATURE SWING COMPARISON

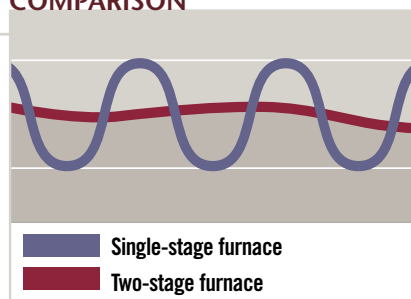

### 3-YEAR HEATING SAVINGS

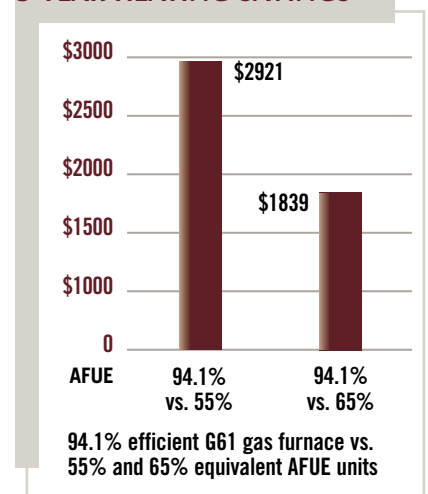

### EFFICIENCY RATING

94.1% AFUE (Annual Fuel Utilization Efficiency).

### WARRANTY

Limited lifetime warranty on the heat exchanger.

5-year limited warranty on all remaining covered components.

## Efficient More comfort for your energy dollar

With its two-stage design, the G61 not only keeps you warm – it reduces your energy costs. With an efficiency rating of 94.1% AFUE (Annual Fuel Utilization Efficiency), compared with older 55% AFUE units, the G61 can save you about \$3,000 in three years.

This chart depicts potential energy savings you can expect from the G61 gas furnace versus older furnaces with lower efficiency ratings. Criteria used in this example are 2,000 full-load heating hours, with a 60,000-Btuh heating design load and \$1.074 ccf for gas. Your actual savings will vary depending on the weather, local fuel rates and your lifestyle. Source: U.S. Department of Energy national average energy rates.

## INNOVATIVE FEATURES FOR ENHANCED COMFORT AND EFFICIENCY

### Duralok Plus® Heat Exchanger –

Made of high-quality, patented ArmorTuf™ aluminized steel. Life-tested to 2-1/2 times agency requirements (ANSI Standard Z21.47) for long life and durability.

### Secondary Heat Exchanger –

Improves efficiency by capturing additional heat.

**Two-Stage Heating** – Provides two levels of heat output for greater temperature control.

### Continuous Low-Speed Fan –

Slowly circulates air for improved comfort and air quality.

### SureLight® Control Board –

Ensures reliable and efficient operation.

**SureLight® Igniter** – Reduces sound for quieter operation.

### Insulated Blower Compartment –

Minimizes operating sounds.

### Durable Steel Cabinet –

Built to last and coated with high-quality, textured-paint finish.

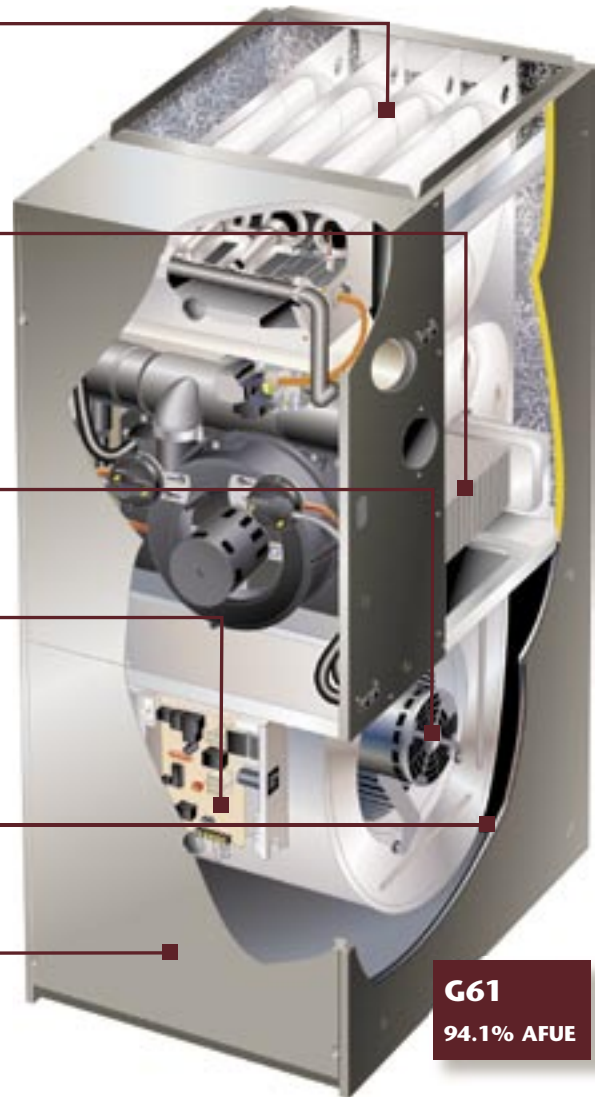

**G61**  
94.1% AFUE

### Elite® Series G61 Specifications

G61	36B-045	36B-070	48C-090	60C-090	48C-110	60C-110	60D-135
AFUE	94.1%	94.1%	94.1%	94.1%	94.1%	94.1%	94.1%
Dimensions							
HxWxD (in.)	40 x 17-1/2 x 28-1/2	40 x 17-1/2 x 28-1/2	40 x 21 x 28-1/2	40 x 21 x 28-1/2	40 x 21 x 28-1/2	40 x 21 x 28-1/2	40 x 24-1/2 x 28-1/2
HxWxD (mm)	1016 x 446 x 724	1016 x 446 x 724	1016 x 533 x 724	1016 x 533 x 724	1016 x 533 x 724	1016 x 533 x 724	1016 x 622 x 724

*Note: Due to Lennox' ongoing commitment to quality, all specifications, ratings and dimensions are subject to change without notice. Warranties noted apply to residential applications only and are limited. Please see actual warranty for details.*

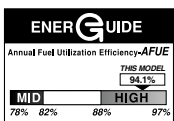

Many Lennox® home comfort systems meet ENERGY STAR® requirements when used with appropriate components. Ask your dealer for details.



Lennox is proud of the fact that these products have earned the Good Housekeeping Seal.





- 1 Air conditioner or heat pump
- 2 Thermostat
- 3 Furnace or air handler
- 4 Filtration device
- 5 Germicidal light
- 6 Indoor coil
- 7 Humidifier
- 8 HEPA bypass filtration system
- 9 Energy recovery ventilator
- 10 Supply duct
- 11 Return duct

## CONTINUOUS COMFORT NETWORK

Lennox® heating, cooling and indoor air quality products are designed to provide efficient, economical comfort—not only as individual units, but also together as an integrated system. This combined network of products delivers on every comfort count, from consistent temperatures and balanced humidity to improved indoor air quality.

## DEALERS YOU CAN COUNT ON

Choosing the right dealer for your heating, cooling and indoor air quality needs is every bit as important as choosing the right brand. We think you'll agree our dealers are a big reason you can count on quality customer service when you call.



**LENNOX**

HOME COMFORT SYSTEMS  
*Innovation never felt so good.™*

© Lennox Industries Inc. 2002

Visit us at [www.lennox.com](http://www.lennox.com), or contact us at 1-800-9-LENNOX.